

Konesali kuntoon: joustoa ja säästöä POWER7-tekniikalla

Pauli Rämö

pauli.ramo@fi.ibm.com





Joustavuus

”Koko järjestelmä on joustava vain, jos kaikki sen komponentit tukevat toisiaan joustavuuden toteuttamisessa”

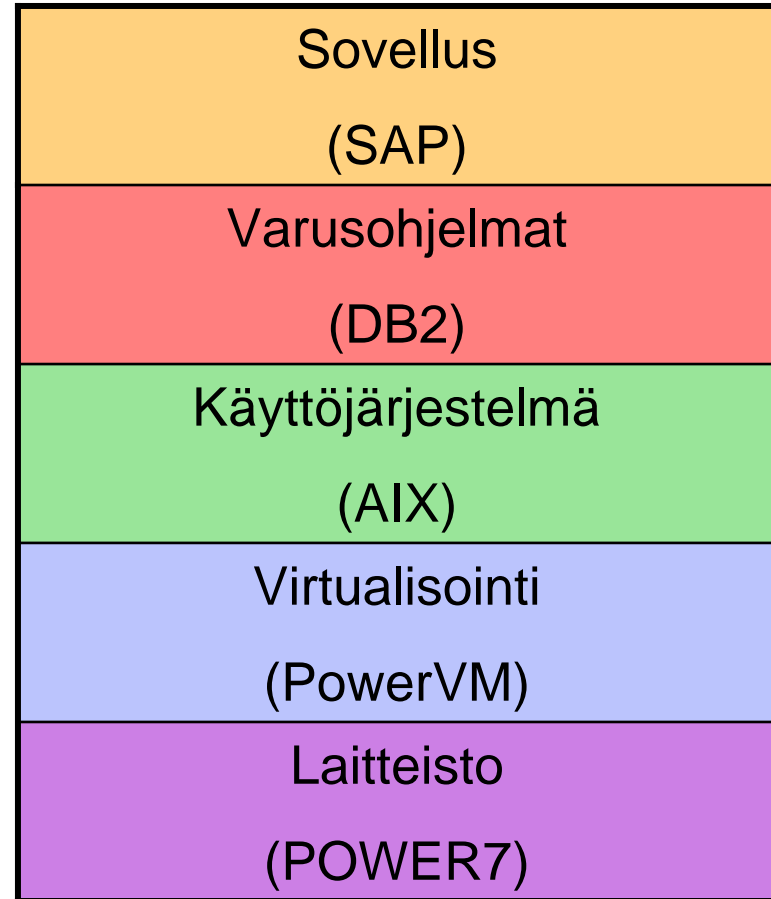

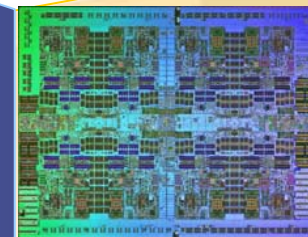
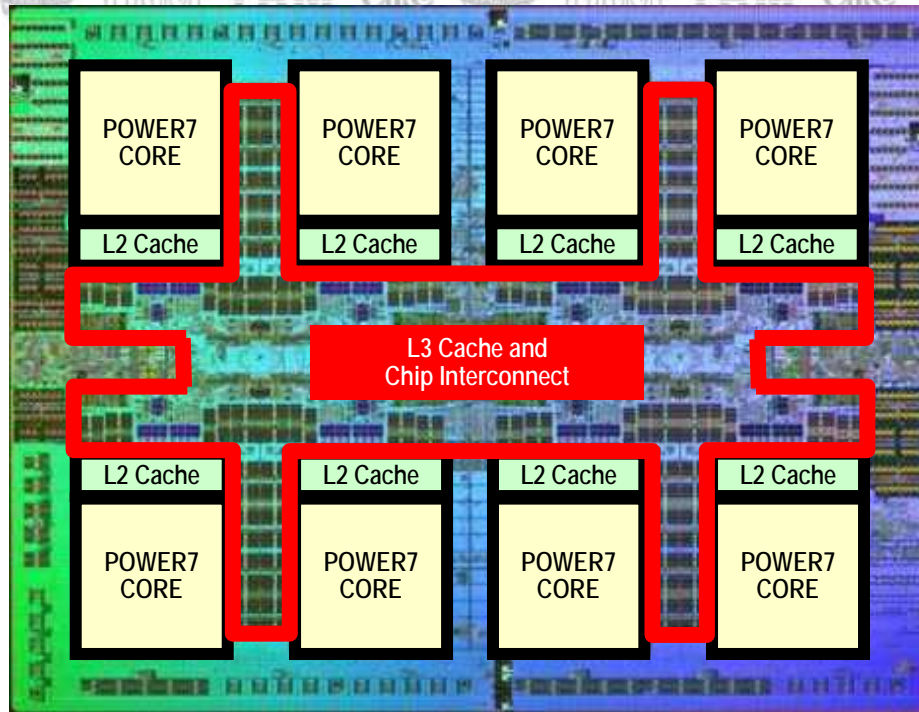

POWER7
45 nm

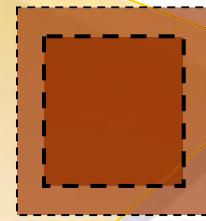

POWER8

8 ydintä
4 way Simultaneous Multi-Threading (SMT)
3-tason välimuisti samalla sirulla
Nopein muistijärjestelmä
Tehokas energian käyttö

- Multi Core
- On-Chip EDRAM
- Power Optimized Cores
- Mem Subsystem ++
- SMT++
- Reliability +
- VSM & VSX
- Protection Keys+

- Concept Phase

2001

2004

2007

2010



POWER7 –tuoteperhe

Power 795

8-256 ydintä*
Max 8TB



Power 780

4-64 ydintä*
Max 2TB



Power 770

4-64 ydintä*
Max 2TB



Power 750

6-32 ydintä
Max 512GB



Power 740

Power 730

4-16 ydintä
Max 256GB



Power 720

Power 710

4/6/8 ydintä
Max 128GB



Power Blades

4/8/16 ydintä
Max 256GB

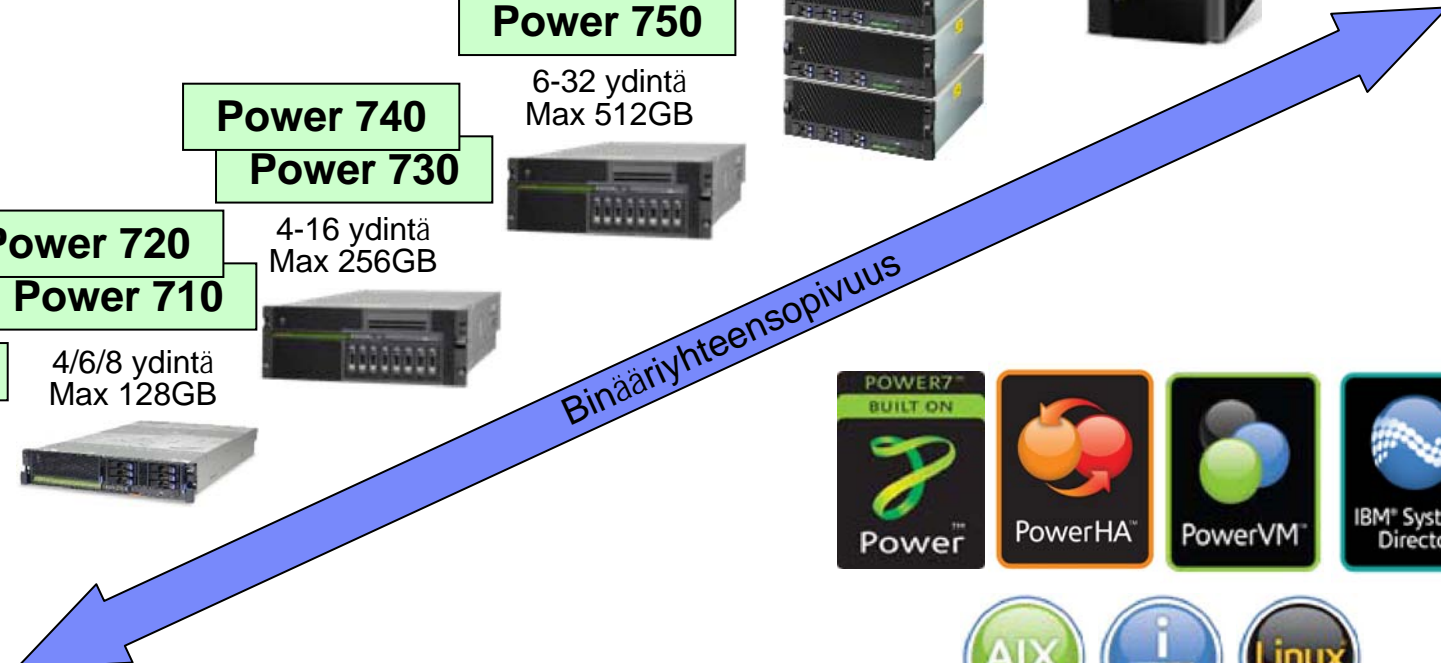

* Capacity-on-Demand-ominaisuuden avulla



Dynaaminen virtualisointi



Kapasiteetin jako sovelluksille dynaamisesti ja automaattisesti

Useita CPU-poleja esim. ohjelmistolisenssien tai eri palveluasiakkaiden rajaamiseen

I/O-virtualisointi SAN- ja LAN-verkkoihin VIOS:ien kautta

Täysi eristävyys virtuaalikoneiden välillä

Tehokas laitteistopohjainen virtualisointi



Virtuaalikoneet eli osiot

Virtuaalikoneiden poolit

Virtualisoitu ja kahdennettu I/O

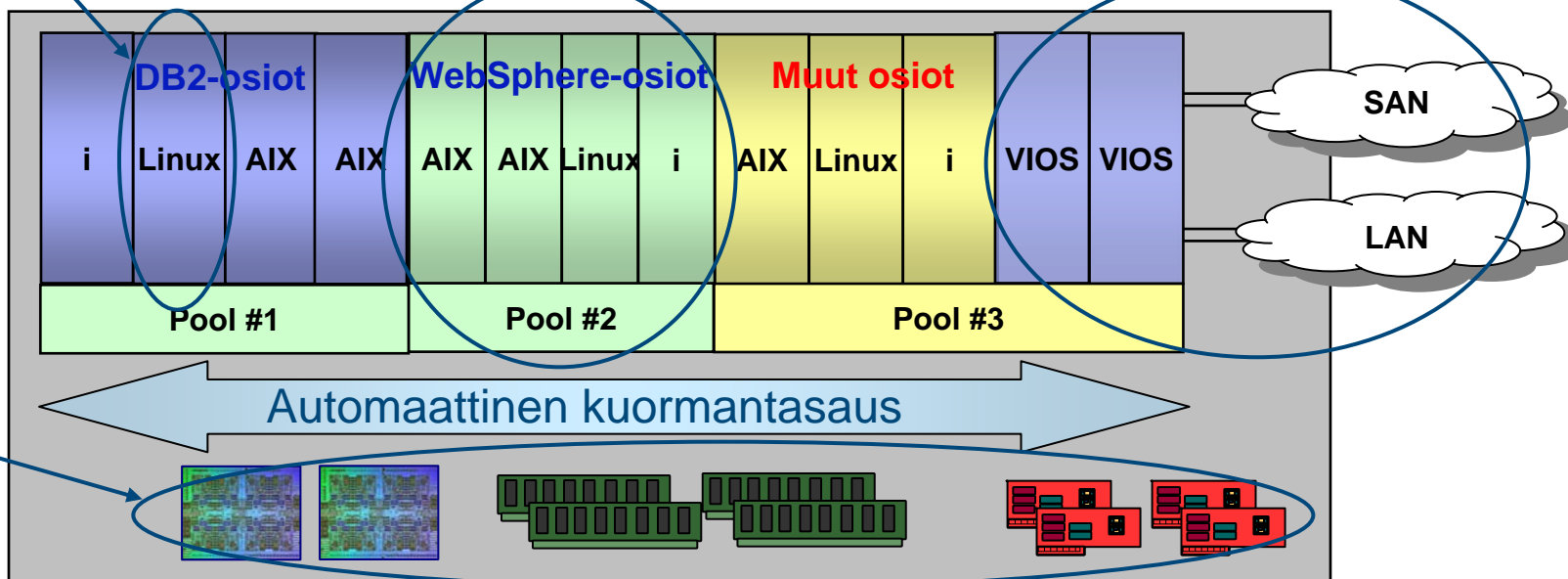

Jaetut resurssit



Capacity on Demand



Palvelimen mukana toimitetaan lisäproessoreita tai muistia (passiivisia) asiakkaan kasvuodotusten mukaisesti tai tyydyttämään satunnaisia tarpeita

Palvelimen passiiviset resurssit otetaan käyttöön automaattisesti ja dynaamisesti määriteltyjen tavoitteiden mukaisesti ilman tuotantokatkoja

Kuormituksenmukainen, pysyvä, väliaikainen tai testiajan aktivointi

Passiiviset Capacity on Demand -resurssit

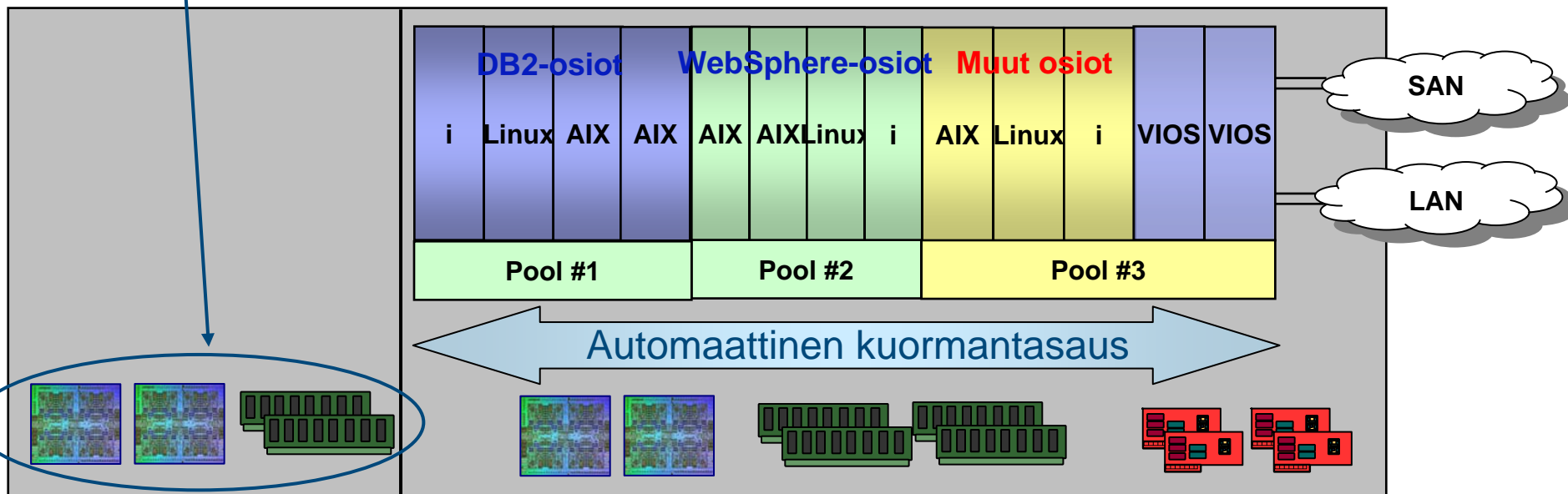



Live Partition Mobility



Osion siirto toiselle palvelimelle ilman tuotantokatkoa

Suunnitellut katkot ilman suurempaa vaikutusta tuotannolle

Työkuormien uudelleen sijoittelu kasvattaessa

Uuden teknologian käyttöönotto ilman tuotantokatkoja

Integroitu VMControl System Pooleihin

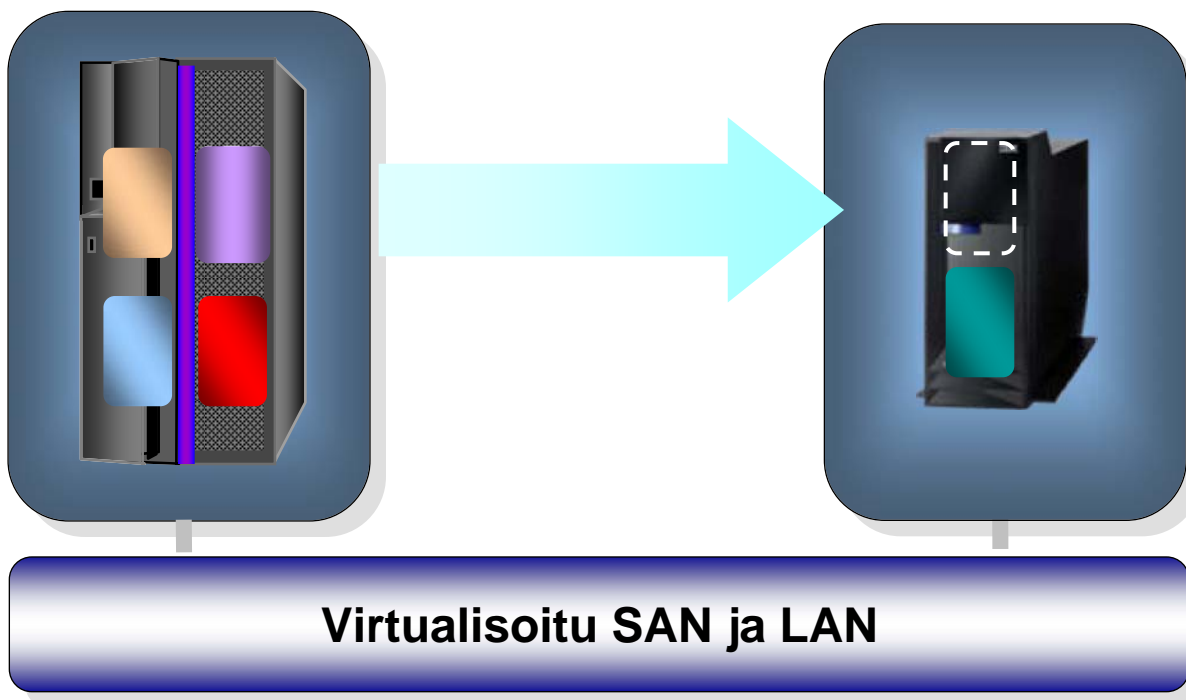



Muistin virtualisointi ja pakkaus



Active Memory Expansion

= muistin pakkaus

Pakkaa keskusmuistin online

Lisää muistia käyttöön olemassa olevalla fyysisellä muistilla tai vähemmän muistia samaan kuormaan

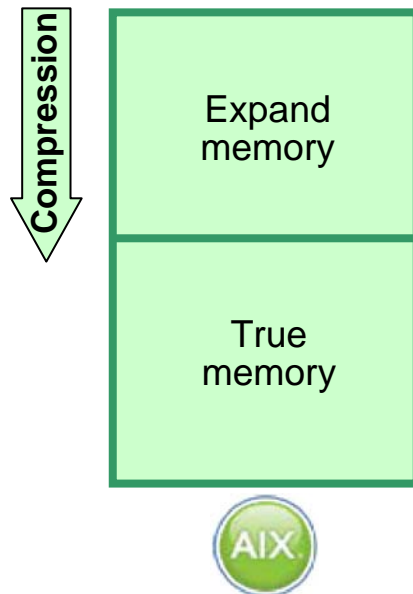

Active Memory Sharing

= muistin virtualisointi

Siirtää muistia osiosta toiseen

Tehokkuus korostuu, jos on erilaisia työkuormia (tuotanto, testi, kehitys, standby)

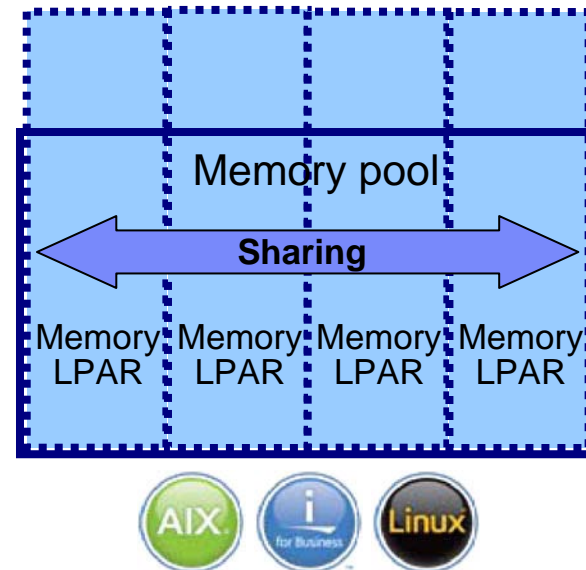



AIX Evolution – Over Twenty years of Progress

1986-1992 1994-1996 1997-1999 2001-2002 2004-2005 2007 2010

AIX/6000



AIX V2 & V3

Establishment in the market:

- RISC Support
- UNIX credibility
- Open Sys. Stds..
- Dynamic Kernel
- JFS and LVM
- SMIT

AIX V4.1/4.2

SMP Scalability:

- POWERPC spt.
- 4-8 way SMP
- Kernel Threads
- Client/Server pkg
- NFS V3
- CDE
- UNIX95 branded
- NIM
- > 2GB filesystems
- HACMP Clustering
- POSIX 1003.1, 1003.2, XPG4
- Runtime Linking
- Java 1.1.2

AIX V4.3

Higher levels of scalability:

- 24-way SMP
- 64-bit HW support
- 96 GB memory
- UNIX98 branded
- TCP/IP V6
- IPsec
- Web Sys. Mgr.
- LDAP Dir. Server.
- Workload Mgr
- Java JDT/JIT
- Direct I/O
- Alt. Disk Install
- Exp/Bonus CDs

AIX 5L V5.1/5.2

Flexible Resource Management:

- POWER4+ spt.
- **Dynamic LPAR**
- **Dynamic CUoD**
- New 64bit kernel
- 512GB mem
- JFS2
- 16 TB filesystems
- UNIX03 branded
- Concurrent I/O
- MultiPath I/O
- Flex LDAP Client
- XSSO PAM spt

AIX 5L V5.3

Advanced Virtualization:

- POWER5 support
- 64-way SMP
- SMT
- **MicroPartitions™**
- **Virt I/O Server**
- Partition Load Mgr
- NFS Version 4
- Adv. Accounting
- Scaleable VG
- JFS2 Shrink
- SUMA
- SW RAS features
- POSIX Realtime

AIX 6

Enterprise RAS:

- POWER6 support
- Workload Partitions
- Application Mobility
- Continuous Avail.
 - Storage Keys
 - Dynamic tracing
 - Software FFDC
 - Recovery Rtns
 - Concurrent MX
- Trusted AIX
- RBAC
- Encrypting JFS2
- AIX Security Expert
- Director Console

AIX 7

Future of UNIX:

- 256 core/1024 thread scalability
- POWER7 Exploitation
- Domain based RBAC
- AIX Profile Manager
- WPAR enhancements
- AIX 5.2 in a WPAR
- PowerVM virtualized storage
- LVM SSD support
- Terabyte segment

Open Systems Workstations
Uni-processor

Distributed Client-Server
4-8 way SMP

Network Centric Computing
24-way SMP

e-Business Computing
32-way SMP

On Demand Business
64/256-way SMT

New Enterprise Data Center
1024-way SMT4

Smarter Planet
1024-way SMT4

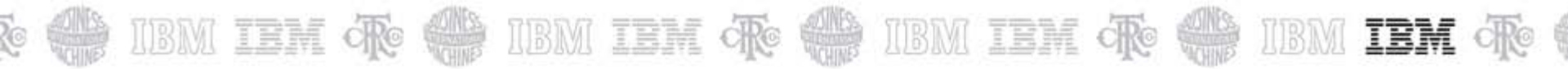

Kustannustehokkuus

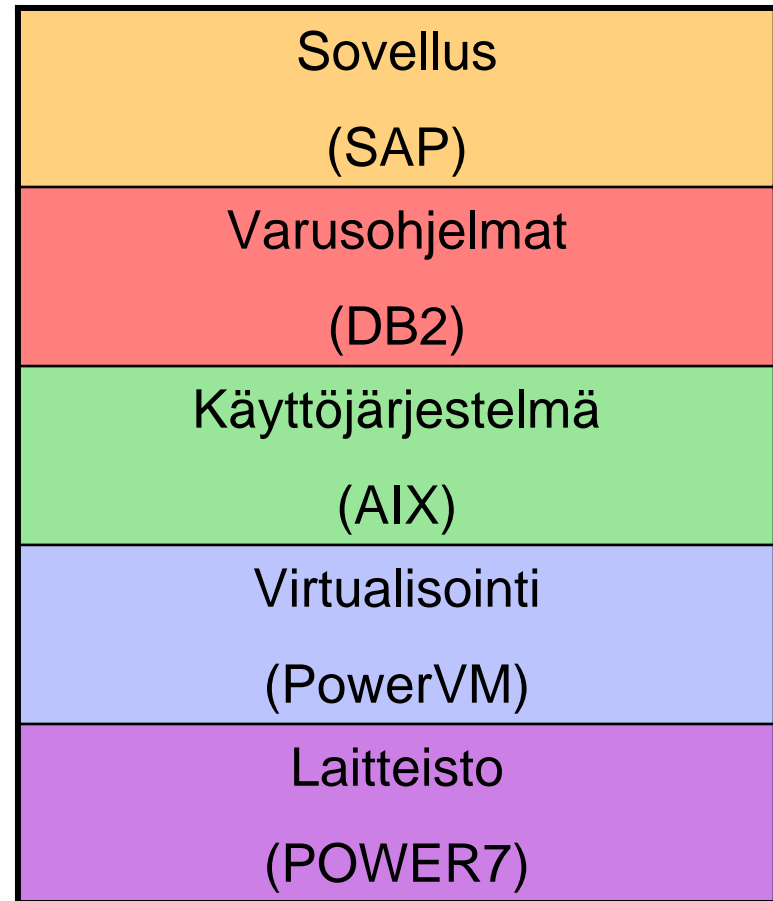



Nopein SAP-palvelin = POWER7

SAP users on SAP SD
2 Tier (BS7)

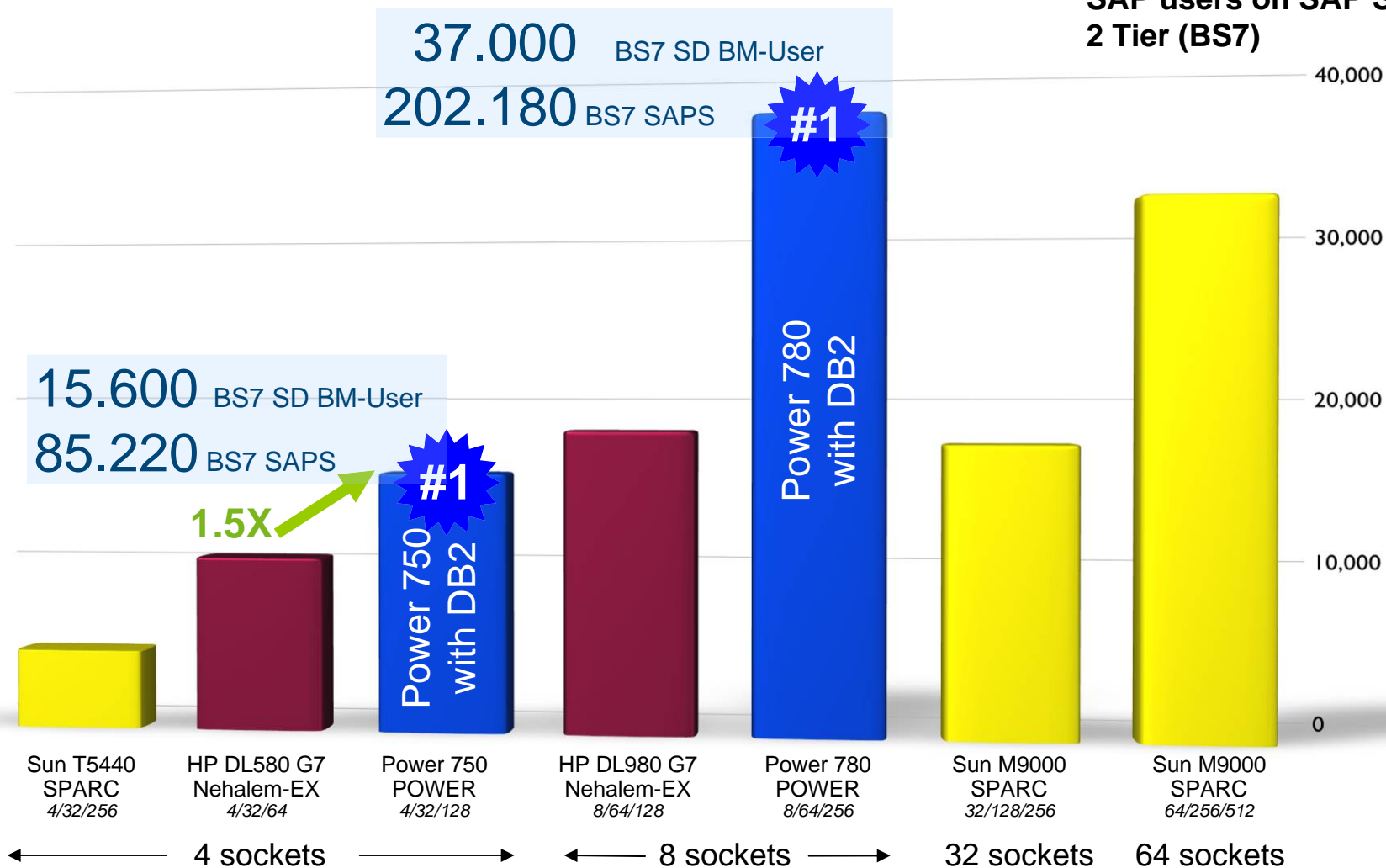

Systems are listed with processor chips/core/threads under system name; IBM Power System 780, 8p / 64-c / 256-t, POWER7, 3.8 GHz, 1024 GB memory, 37,000 SD users, dialog resp.: 0.98s, line items/hour: 4,043,670, Dialog steps/hour: 12,131,000, SAPS: 202,180, DB time (dialog/update): 0.013s / 0.031s, CPU utilization: 99%, OS: AIX 6.1, DB2 9.7, cert# 2010013; SUN M9000, 64p / 256-c / 512-t, 1156 GB memory, 32,000 SD users, SPARC64 VII, 2.88 GHz, Solaris 10, Oracle 10g, cert# 2009046; All results are 2-tier, SAP EHP 4 for SAP ERP 6.0 (Unicode) and valid as of 7/13/2010; Source: <http://www.sap.com/solutions/benchmark/sd2tier.epx> - See Power 780 benchmark details for more information



Eniten suorituskykyä samalla energialla



Ensimmäinen Energy Star –sertifioitu Unix-järjestelmä säästää sähköä

Power 750



Most energy efficient systems

Performance Per Watt

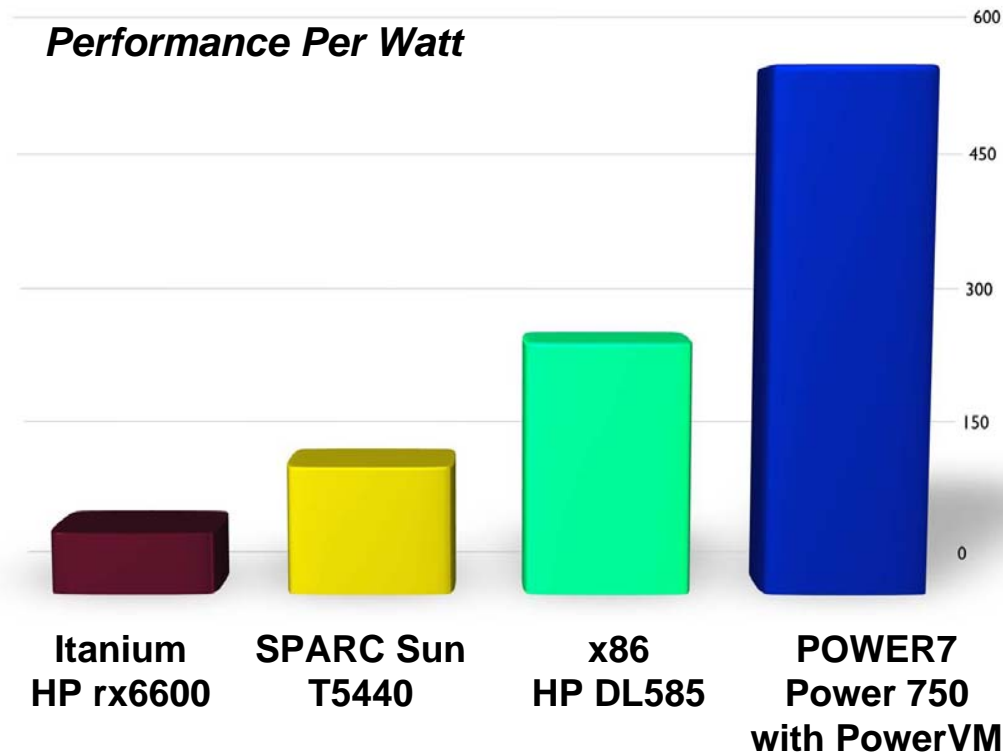



Kustannukset kuriin



SAP and DB2 on Power 750

3.3x More SD users on DB2 and Power 750 than Oracle on SPARC T5400

SAP Sales and Distribution ERP 6.0 EHP4 2-Tier performance

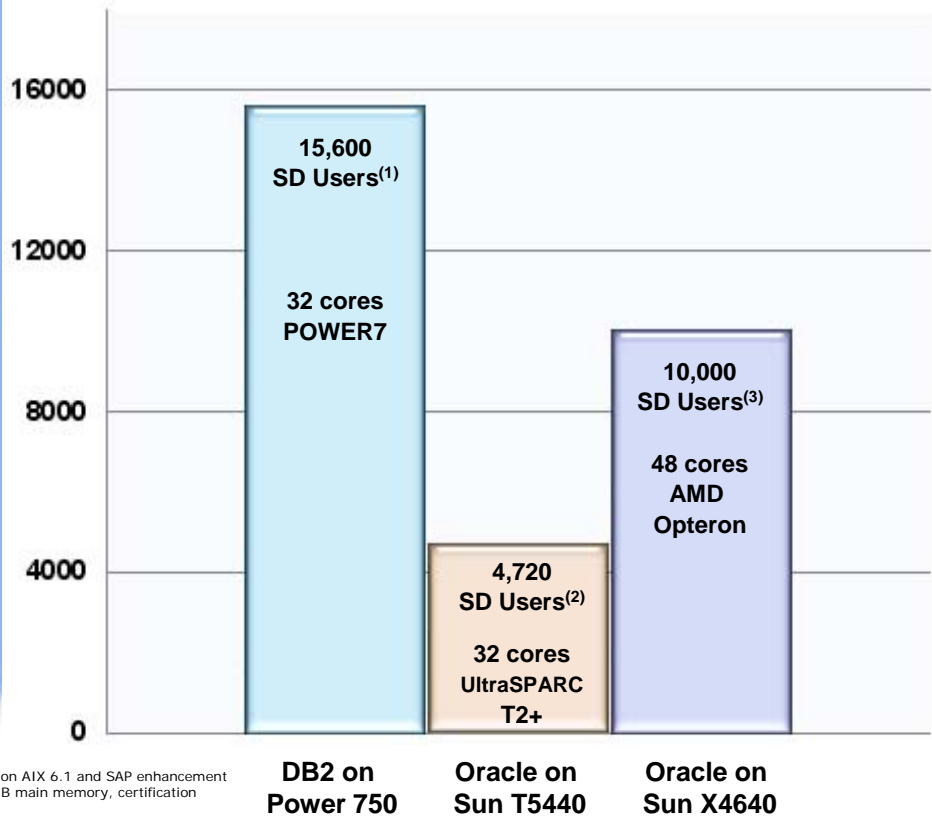

(1) IBM SAP 2-Tier SD result of 15,600 SD (Sales & Distribution) users (Average dialog response time: 0.98 second), running DB2 9.7 on AIX 6.1 and SAP enhancement package 4 for SAP ERP 6.0 on the IBM Power System 750 with 4 POWER7 3.55 GHz processor chips (32 cores, 128 threads) and 256 GB main memory, certification Number: 2010004. For more details, see <http://www.sap.com/benchmark>.

(2) Sun Microsystems SAP 2-Tier SD result of 4,720 SD (Sales & Distribution) users (Average dialog response time: 0.97 second), running Oracle 10g on Solaris 10 and SAP enhancement package 4 for SAP ERP 6.0 (Unicode) on the SPARC Enterprise T5440 with 4 UltraSPARC T2 Plus 1.6 GHz processor chips (32 cores, 256 threads) and 256 GB main memory, certification Number: 2009026. For more details, see <http://www.sap.com/benchmark>.

(3) Sun Microsystems SAP 2-Tier SD result of 10,000 SD (Sales & Distribution) users (Average dialog response time: 0.90 second), running Oracle 10g on Solaris 10 and SAP enhancement package 4 for SAP ERP 6.0 (Unicode) on the Sun Fire X4640 with 8 AMD Opteron B435 Processors at 2.6 GHz (48 cores, 48 threads) and 256 GB main memory, certification Number: 2009049. For more details, see <http://www.sap.com/benchmark>.

(1) (2) (3) Results as of 3/29/2010





Käytettävyys

”Koko järjestelmä on niin luotettava kuin sen heikoin lenkki”

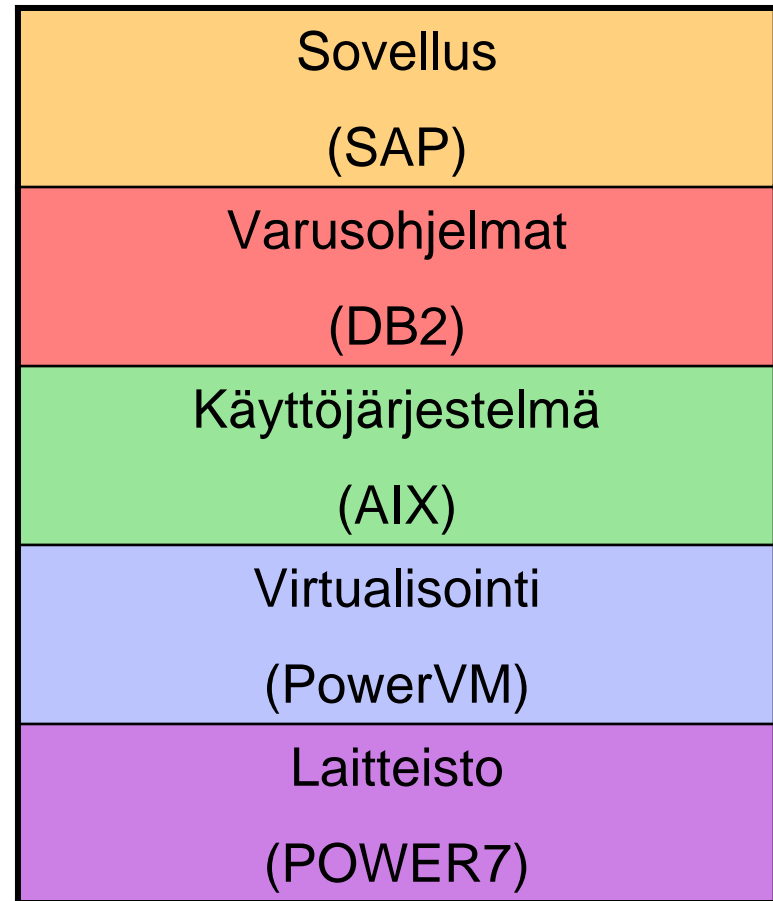



Power Systems + AIX: 99.997% käytettävyys



54% IT-johdajista vaatii vähintään 99.99% käytettävyyttä sovelluksilleen

Power Systems with AIX delivers the best RAS of UNIX, Linux, and Windows

1. Availability: The least amount of downtime

- **15 minutes a year**
- 2.3 times better than the closest UNIX competitor
- more than 10X better than Windows

2. Reliability: The fewest unscheduled outages

- **less than one outage per year**

3. Serviceability: The fastest patch time

- **11 minutes to apply a patch**
- 2.5 times better than the closest UNIX competitor
- 3 times better than Windows

Minutes of downtime per year

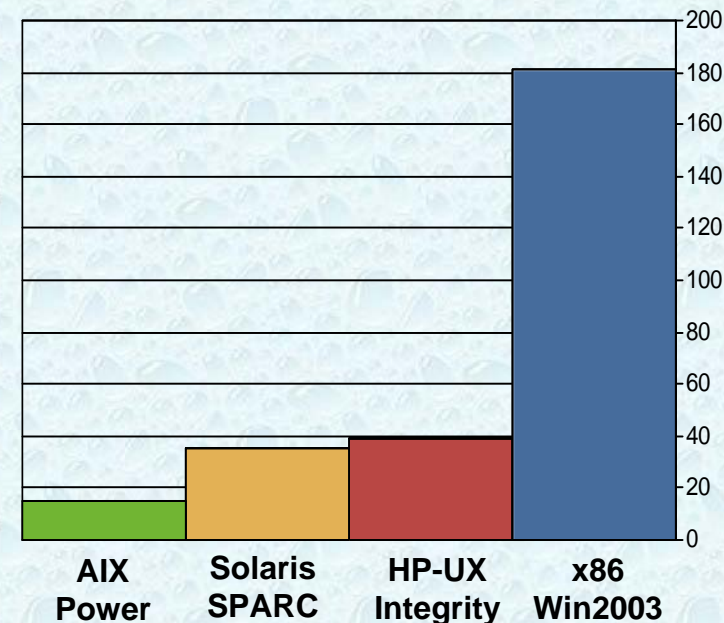

Source: [ITIC 2009 Global Server Hardware & Server OS Reliability Survey Results](#), July 7, 2009



Tietoturva

Common Criteria Assurance Levels*

CAPP/EAL4+ taso : AIX, IBM i, PowerVM, Virtual I/O Server

- AIX käyttöjärjestelmä vuodesta 2003 lähtien
- Power virtualisointi vuodesta 2004 lähtien



IBM operating systems and Power virtualization, designed to be the most secure in the world**

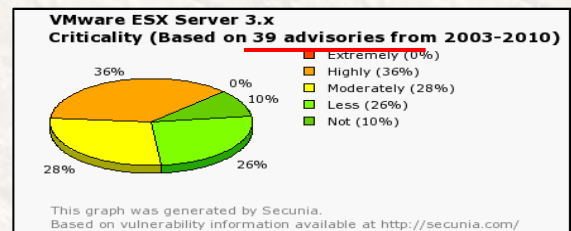
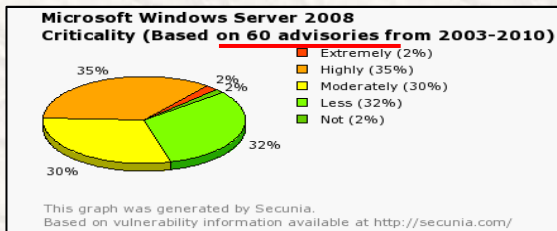
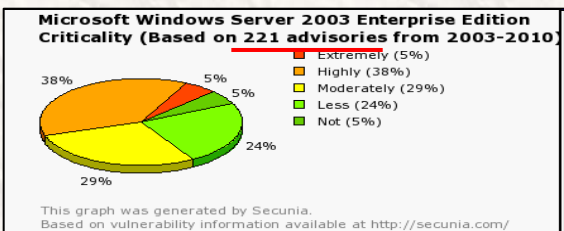
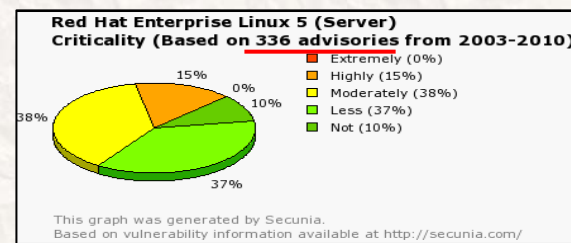
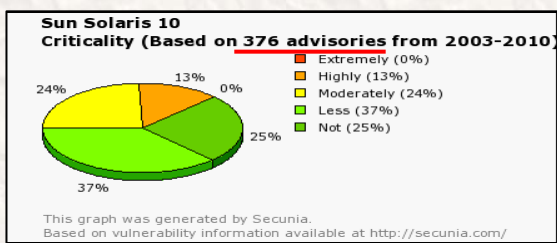
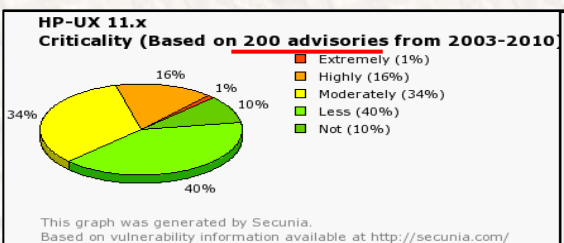
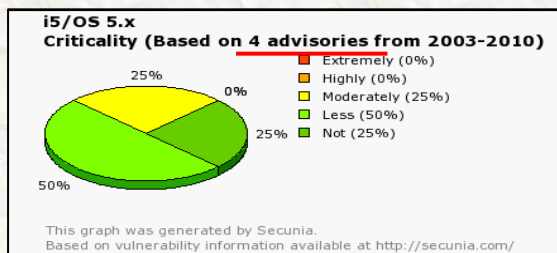
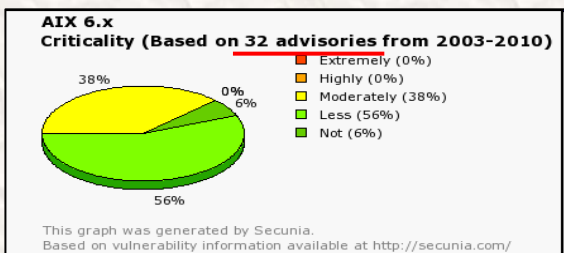

**based on vulnerability information available at <http://secunia.com/>

Käytännön esimerkki – HA-konfiguraatio

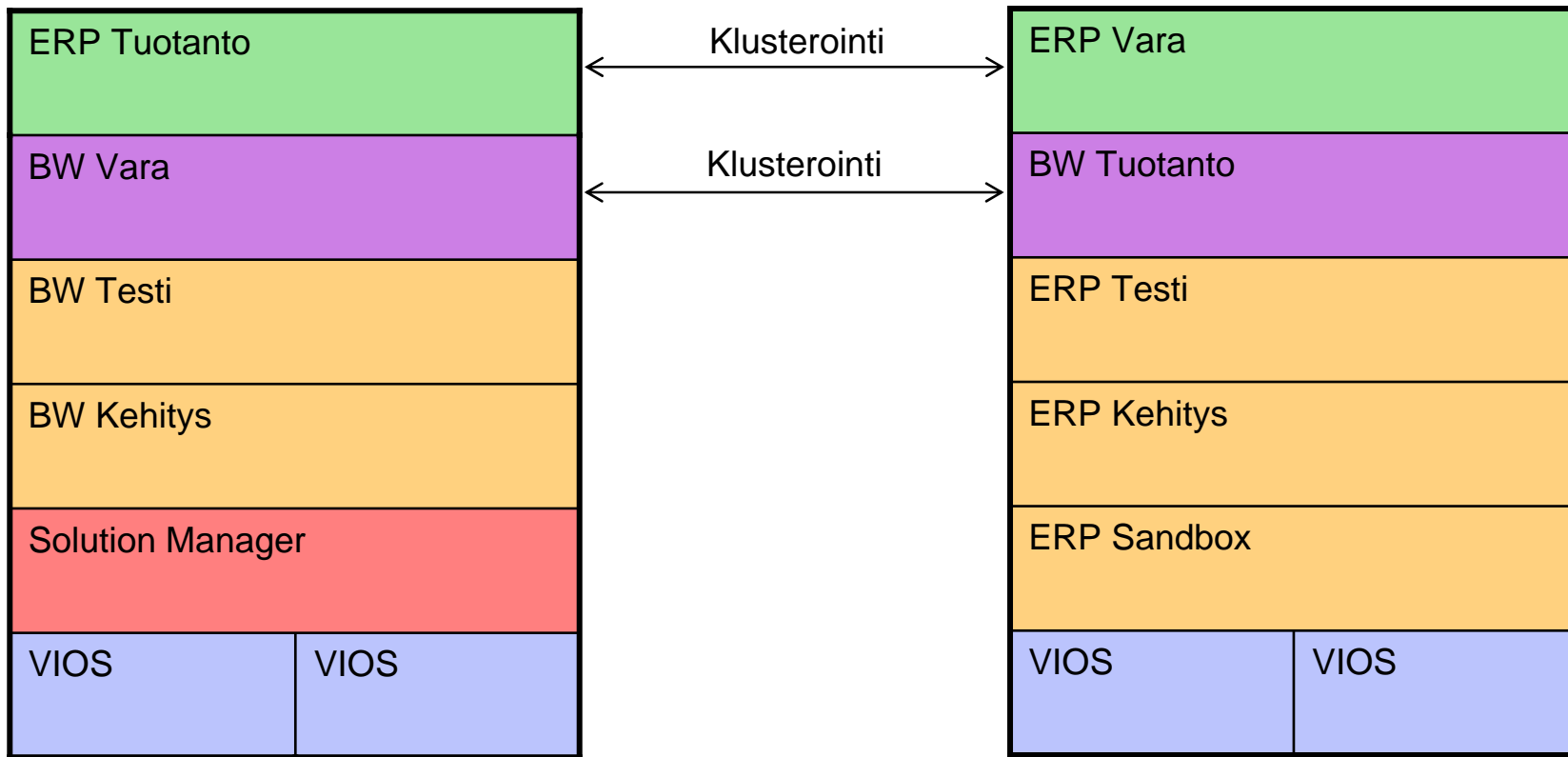



Kiitos

Kysymyksiä?